

ISOMAG ™

The friendly magmeter

ALPHANUMERIC CONVERTER

ML 110



ALPHANUMERICAL DISPLAY CONVERTER

Warranty conditions are available on this website:
www.isomag.eu only in English version

ISOIL 
INDUSTRIA
The solutions that count

INDEX

TECHNICAL DATA	3
OVERALL FEATURES	3
STANDARD FEATURES	3
OPTIONAL FEATURES	4
ACCURACY	4
OVERALL DIMENSIONS	5
VISUALIZATION PAGES	6
ELECTRICAL CONNECTIONS	7
FUNCTIONS	8
ACCURACY TABLE	10
MS110: MI-001 DETAILS	11
HOW TO ORDER	14

TECHNICAL DATA

<i>OVERALL FEATURES</i>	
Suitable For	<input type="checkbox"/> All the ISOMAG sensors
Minimum conductivity	<input type="checkbox"/> 5 μS/cm
Altitude	<input type="checkbox"/> -200 m up to 2000 m
Ambient Temperature	<input type="checkbox"/> -10... +50°C / -14... +122°F
Humidity Range	<input type="checkbox"/> 0÷100% (IP 67)

<i>STANDARD FEATURES</i>	
Housing materials	<input type="checkbox"/> Nylon PA6 with fiber of glass
Version	<input type="checkbox"/> Compact
Protection Rate	<input type="checkbox"/> IP 65
Power supply/Consumption	<input type="checkbox"/> 100-240 V\sim 44-66 Hz
Cable gland	<input type="checkbox"/> N° 3 Cable gland PG 11
Full scale value	<input type="checkbox"/> 0,4...10m/s
Protocols	<input type="checkbox"/> ETP
Pulses/frequency outputs	<input type="checkbox"/> N°2 , 1250 Hz, 100mA, 40 Vdc
Dig. Input / Alarm output	<input type="checkbox"/> Programmable function
Galvanic Isolation	<input type="checkbox"/> All the inputs/outputs are galvanically isolated from power supply up to 500 V
Data Storage	<input type="checkbox"/> Eeprom values storing system in case of power failure
Programming Plug In	<input type="checkbox"/> Protected plug in for the connection to PC or hand terminal
Bi-Directional	<input type="checkbox"/> Yes
Dual Range	<input type="checkbox"/> Yes
Diagnostic Funct.	<input type="checkbox"/> Yes
Empty Pipe Detect.	<input type="checkbox"/> Yes
CE Certification	<input type="checkbox"/> Yes

OPTIONAL FEATURES (CHECK HOW TO ORDER, AT LAST PAGE, FOR MORE DETAILS)	
Housing materials	<input type="checkbox"/> Painted aluminium die casting
Version	<input type="checkbox"/> Separate
Protection Rate	<input type="checkbox"/> IP 67 (Aluminium housing)
Conn. sensor cable	<input type="checkbox"/> CABLE C018
LCD Display	<input type="checkbox"/> Alphanumerical display 16 characters x 2 lines no back light
Keyboard	<input type="checkbox"/> 3 internal keys
Power Supply/Consumption	<input type="checkbox"/> 18-45V $\overline{\text{---}}$ / \sim (6W – 7VA)
Pulses/ Alarm Outputs	<input type="checkbox"/> N°2 , 1250 Hz, 100mA, 40 Vdc (12,5 KHz Opt.) <input type="checkbox"/> Relais
Current Output	<input type="checkbox"/> N°1 , 0/4...20mA – RL=800 Ω
Communication port	<input type="checkbox"/> RS 485
Protocols	<input type="checkbox"/> Modbus
Certification	<input type="checkbox"/> MI-001

ACCURACY	
Measurements tolerance	<input type="checkbox"/> Flow rate (volume) = $\pm 0,1\%$ v.l. <input type="checkbox"/> Out 4/20 mA = $\pm 0,12\%$ v.l. <input type="checkbox"/> Frequency Out = $\pm 0,12\%$ v.l.
Repeatability	<input type="checkbox"/> Better than $\pm 0,2\%$
Accuracy (whole system converter+sensor)	<input type="checkbox"/> See table below

OVERALL DIMENSIONS

COMPACT VERSION (NYLON)

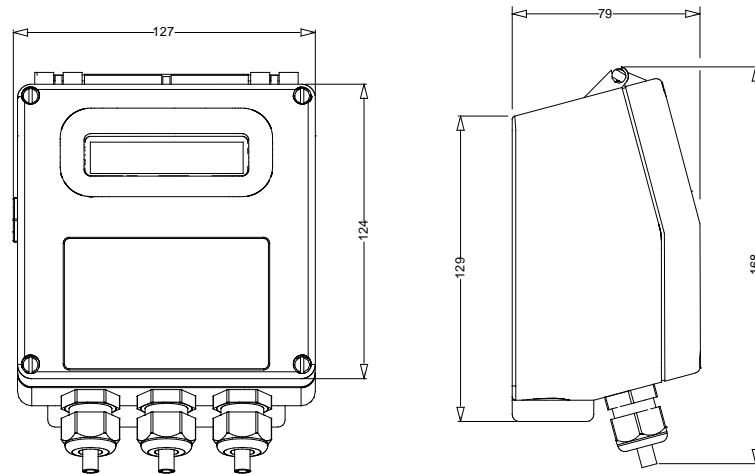

COMPACT VERSION (ALUMINIUM)

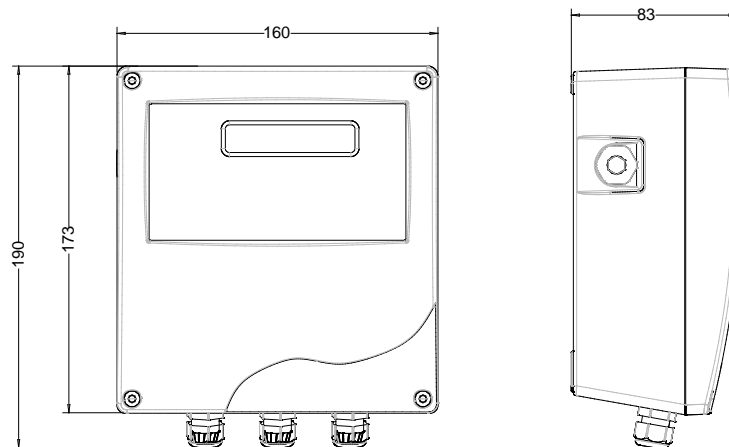

SEPARATE VERSION

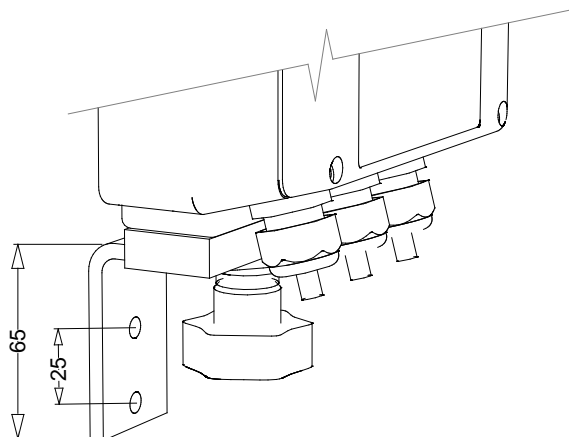

VISUALIZATION PAGES

→	dm^3/s +5.000 !S +100.0% ████████	Flow rate value t.u. and %
→	$T+\text{dm}^3!$ 10189.671 $P+\text{dm}^3!$ 10189.671	Totalized values
→	$T+\text{dm}^3!$ 10564.671 $T-\text{dm}^3!$.000	Direct and reverse totalized
→	dm^3/s +5.000 !S m/s 10.19 ████████	Flow rate and liquid speed
→	=====> <=====	Scrolling visualization
↑	EXCITATION FAIL	Alarm ON visualization

Different visualization possibilities with a simple press of a key

ELECTRICAL CONNECTIONS

TERMINAL BLOCK VIEW

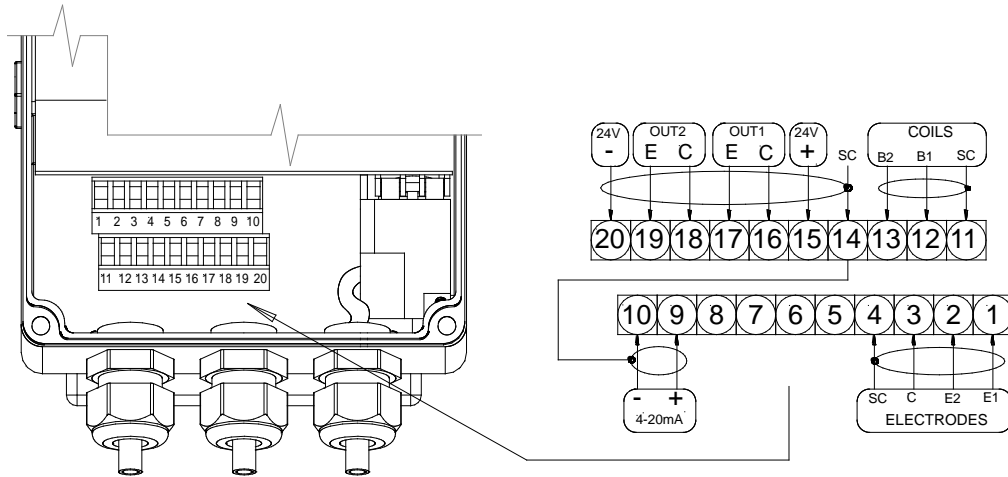

ON/OFF OUTPUT

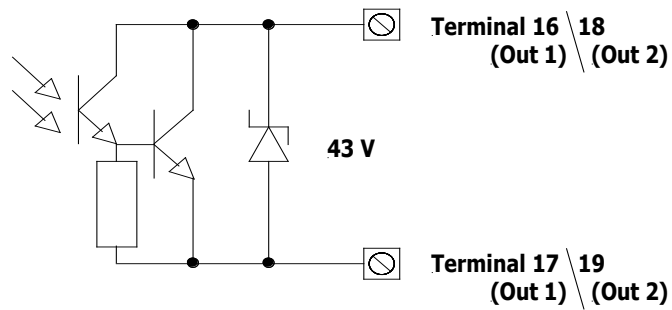

ANALOG OUTPUT

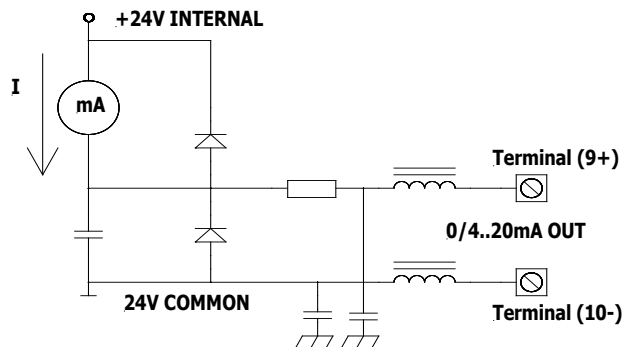

FUNCTIONS

MAIN MENU 1-Sensor

```

1-SENSOR
ND=mm      00025
KA=        +01.0000
Sens.type= 00
Ins.Position= 0
Ki=        1.0000
Kf=        1.0000
Cable len.=m 00
S.rate=Hz  50
U.ref=     255
U.reg=     040
E.P.detect= OFF
E.cleaning= OFF
E.P.thr.=  200
Autozero cal.
  
```

- 1.1 Sensor Nominal Diameter (ND), (enter input value 0-3000 mm)
- 1.2 Sensor calibration data (Enter value as specified on sensor label)
- 1.3 Type of sensor: Enter the first two characters of the sensor serial number
- 1.4 Position of insertion sensor: 0=1/8DN, 1=1/2DN, 2=7/8DN
- 1.5 Factory parameters automatically calculated (ONLY for insertion sensors)
- 1.6 Length of the cable connecting the sensor to the transmitter
- 1.7 Sample rate
- 1.8 (only for service purpose)
- 1.9 (only for service purpose)
- 1.10 Enables the empty pipe detection feature
- 1.11*Electrodes cleaning
- 1.12*Value of empty pipe sensibility detection
- 1.13* Enables the automatic procedure of zero calibration

MAIN MENU 2-Scales

```

2-SCALES
Fs1=dm³/s  05.000
Fs2=dm³/s  05.000
Tot.MU=dm³ 1.000
Pls1=dm³   01.0000
Pls2=dm³   01.0000
Tpls1=ms   0050.00
Tpls2=ms   0050.00
Frac1=Hz   01000.00
Frac2=Hz   01000.00
Sg=kg/dm³ 01.0000
  
```

- 2.1* Full scale value set for range N.1
- 2.2* Full scale value set for range N.2
- 2.3* Unit of measure and number of decimal place
- 2.4* Pulse value on channel 1
- 2.5* Pulse value on channel 2
- 2.6* Duration of the pulse generated on channel 1
- 2.7* Duration of the pulse generated on channel 2
- 2.8 Full scale frequency for channel 1 (0.1Hz-1000.0Hz)
- 2.9 Full scale frequency for channel 2 (0.1Hz-1000.0Hz)
- 2.10 Volume to mass specific gravity coefficient set in kg/dm³

MAIN MENU 3-Measure

```

3-MEASURE
AC Filter=s 0.2
M.filter=s  020.0
Cut-off=%   02.0
Autocal.=   OFF
Autorange=  ON
E.saving=   OFF
  
```

- 3.1* Main frequency filter
- 3.2* Measure filter
- 3.3 Low flow zero threshold: 0-25% of full scale value
- 3.4 Enable automatic hourly internal calibration cycle. Measurement stopped for 8-15s.
- 3.5* Automatic change of scale
- 3.6* Energy saving function

MAIN MENU 4-Alarms

```

4-ALARMS
Max thr=%  000
Min thr=%  000
Hyst.=%    03
mA v.fault=% 010
Hz v.fault=% 125
  
```

- 4.1 Maximum flow rate value alarm setting
- 4.2 Minimum flow rate value alarm setting
- 4.3 Hysteresis threshold setting for the minimum and maximum flow rate alarms
- 4.4* Current output value in case of failure
- 4.5* Frequency output value in case of failure

MAIN MENU 5-Inputs

```

5-INPUTS
T+ reset=  OFF
P+ reset=  OFF
T- reset=  OFF
P- reset=  OFF
Count lock= OFF
Calibration= OFF
Range change= OFF
  
```

- 5.1* Total direct (positive) flow totalizers reset enable
- 5.2* Partial direct (positive) flow totalizers reset enable
- 5.3* Total reverse (negative) flow totalizers reset enable
- 5.4* Partial reverse (negative) flow totalizers reset enable
- 5.5 Totalise counting lock command (see input on/off operation section)
- 5.6* Autozero calibration external command
- 5.7 Range change external command (see function 3.5)

MAIN MENU
6-Outputs

```
6-OUTPUTS
Out1= #1 FREQ
Out2= #2 FREQ+
Out mA1=4.22
```

- 6.1* Output 1 functions
- 6.2* Output 2 functions
- 6.3* Choice of function the range of current output n.1

MAIN MENU
7-Communication

```
7-COMMUNICATION
IF2 prot.= DPP
Pr.RS485= DPP
RS485 bps= 4800
Parity= EVEN
Address= 000
A.delay=ms 0
```

- 7.1 Choice of the communication protocol for the IF2 device
- 7.2 Choice of the communication protocol for the RS485 port
- 7.3 Speed of the RS485 output (possible choice: 4800, 9600, 19200, 38400 bps)
- 7.4 RS485 parity
- 7.5 Address value of the converter (range 0 - 255)
- 7.6 Instrument answer delay

MAIN MENU
8-Display

```
8-DISPLAY
Language= EN
D.rate=Hz 1
Contrast= 7
Quick start= OFF
Net total.= OFF
Currency= ON
Curr.decim.= 2
EUR/dm³= 01.0000
EUR/dm³= 01.0000
T+ reset
P+ reset
T- reset
P- reset
```

- 8.1 Choice of the language: EN= English, IT=Italian, FR= French, ES= Spanish, DE=German
- 8.2 Display updating frequency: 1-2-5-10 Hz
- 8.3 Display contrast
- 8.4 Quick start menu visualization
- 8.5 Enable the page of net totalizer
- 8.6 Visualizes the values of the partial totalizer in the unit of selected currency
- 8.7 Choice of the numbers of decimals for the visualization currency value: From 0 to 3
- 8.8* Value of conversion/currency for direct totalizer
- 8.9* Value of conversion/currency for reverse totalizer
- 8.10* Total direct (positive) flow totalizer reset
- 8.11* Partial direct (positive) flow totalizer reset
- 8.12* Total reverse (negative) flow totalizer reset
- 8.13* Partial reverse (negative) flow totalizer reset

MAIN MENU
10-Diagnostic

```
10-DIAGNOSTIC
Calibration
Self test
Simulation= OFF
Firmware rev.
```

- 10.1* Calibration of the converter
- 10.2* Autotest converter
- 10.3* Flow rate simulation enabling
- 10.4 Firmware revision/version

MAIN MENU
11-Internal data

```
11-INTERNAL DATA
L2 keycode=00000
Load fact.pres.
Load user pres.
Save user pres.
Ign.cal.err= OFF
KR= +01.0237
KS= +1.0000
```

- 11.1 Level 2 access code enter (user choice and setting of access code if required)
- 11.2 Load factory data pre-set
- 11.3 Load user data saved
- 11.4 Save user data
- 11.5 Ignore the calibration error during the switch on test (enable/disable)
- 11.6 KR coefficient (only for service purposes)
- 11.7 KS coefficient (only for service purposes)

Note : all page number references are to the operating manual .

ACCURACY TABLE

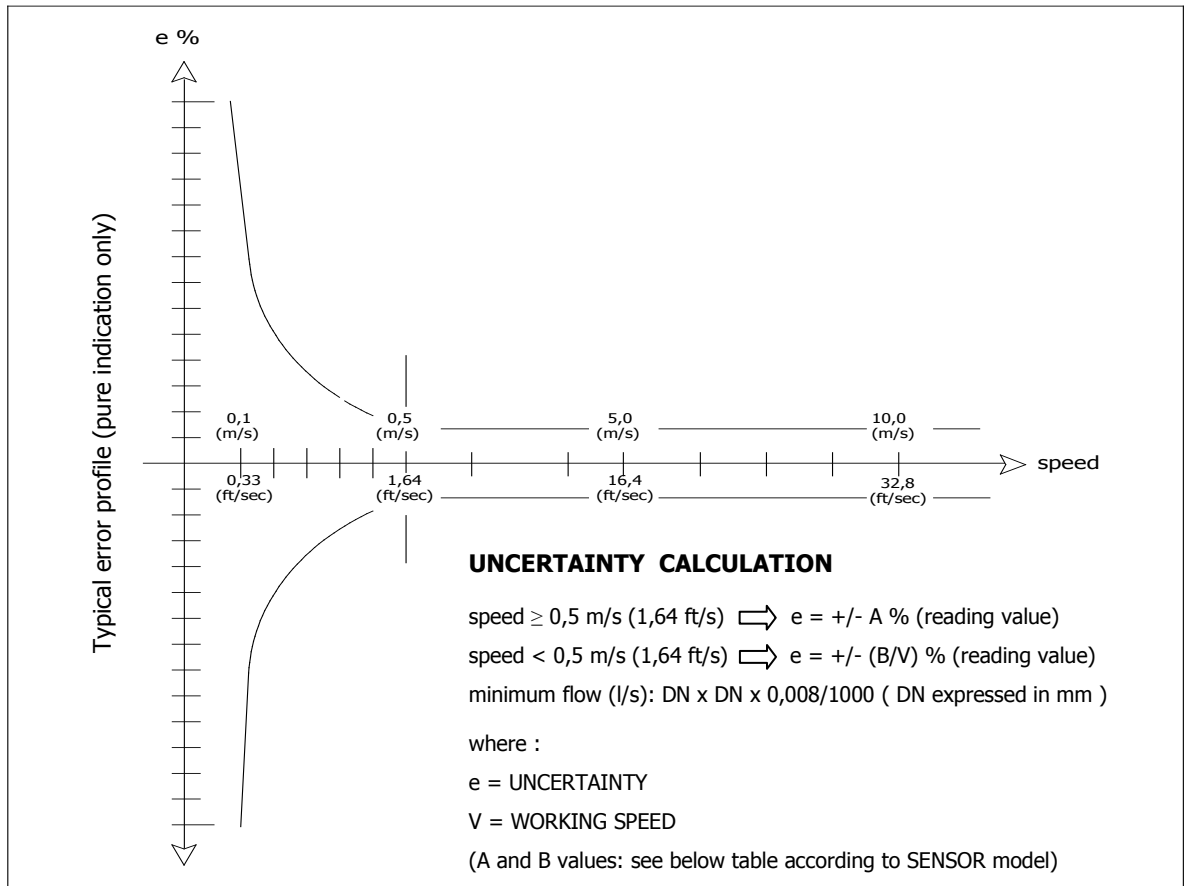

FULL BORE SENSORS

MS501/MS1000/MS2410/MS2500			MS 600			MS5000		
A	B(m/s)	B(ft/s)	A	B(m/s)	B(ft/s)	A	B(m/s)	B(ft/s)
0,8*	0,4**	1,31**	0,8*	0,4**	1,31**	2	1	3,28

* = 0,4 (special)

**= 0,2(m/s) ; 0,66(ft/s) - special

INSERTION SENSORS

See MS 3770 / MS 3800 DATA SHEET

NOTE: Special calibration for improved above accuracy: consult manufacturer

Reference conditions:

- Constant flow rate during the test
- Pressure: >30 Kpa
- Flow condition : fully developed flow profile
- Zero stability +/- 0,005 %

MS110: MI-001 DETAILS

The sensor's diameters listed below, coupled with ML210 and ML110 , are certified according to European Directive 2004/22CE category MI-001 (OIML R49)

Sensor Size	mm	25	32	40	50	65	80	100	125	150	200
	inch	1	1 ¼	1 ½	2	2 ½	3	4	5	6	8
Q1	m ³ /h	0.1	0.156	0.25	0.394	0.625	1	1.563	2.5	3.938	6.25
Q2	m ³ /h	0.16	0.25	0.4	0.63	1	1.6	2.5	4	6.3	10
Q3	m ³ /h	16.0	25.0	40.0	63.0	100.0	160.0	250.0	400.0	630.0	1000
Q4	m ³ /h	20	31.3	50	78.8	125	200	312.5	500	787.5	1250

MI-001 ALLOWABLE RANGE

- Q3 allowed range :

/m ³ h ⁻¹	/dm ³ s ⁻¹	/m ³ h ⁻¹	/dm ³ s ⁻¹	/m ³ h ⁻¹	/dm ³ s ⁻¹	/m ³ h ⁻¹	/dm ³ s ⁻¹	/m ³ h ⁻¹	/dm ³ s ⁻¹
1	0,278	1,6	0,444	2,5	0,694	4	1,111	6,3	1,750
10	2,778	16	4,444	25	6,944	40	11,11	63	17,50
100	27,78	160	44,44	250	69,44	400	111,1	630	175,0
1000	277,8	1600	444,4	2500	694,4	4000	1111	6300	1750

- Q2 /Q1=1,6
- Q4 /Q3=1,25
- R (= Q3/Q1) allowed range :

10	12,5	16	20	25	31,5	40	50	63	80
100	125	160	200	250	315	400	500	630	800

OIML R49 ACCURACY CLASS 2 (Maximum Permissible Error)

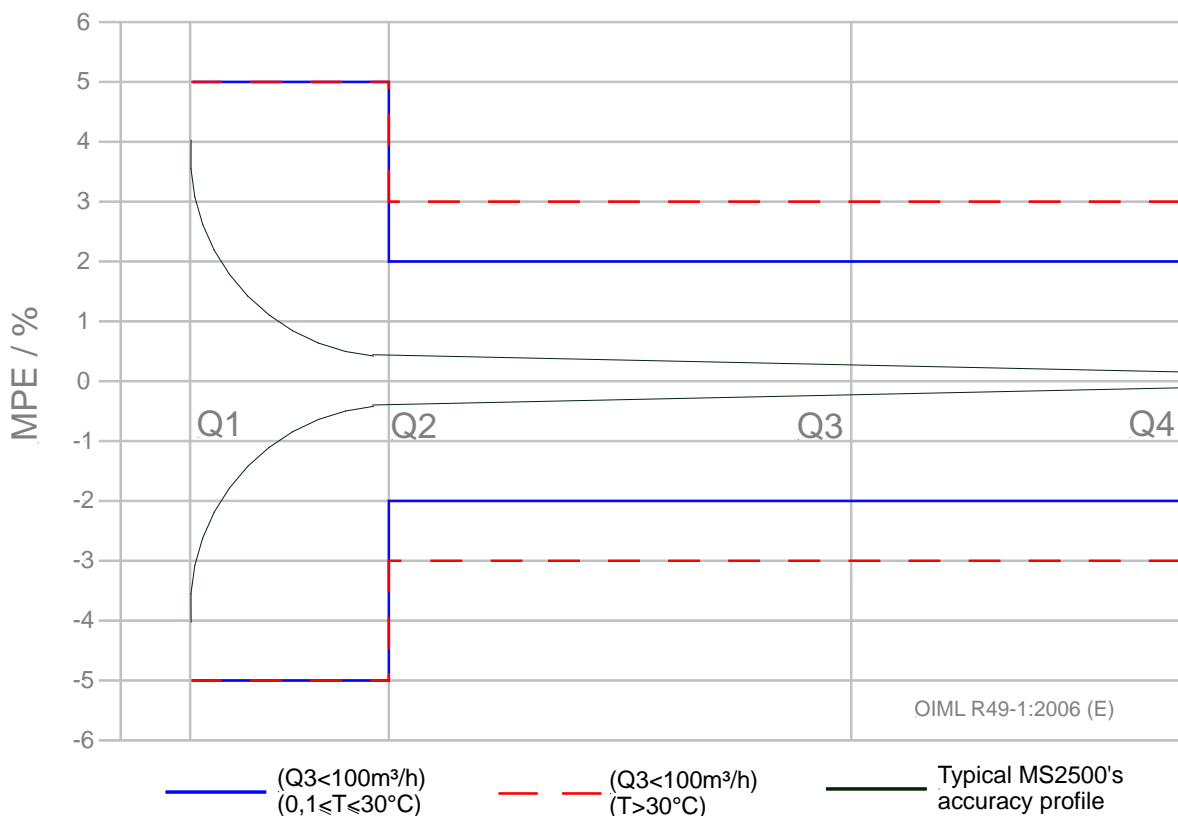

MS2500: MI-004

The sensor's diameters listed below, coupled with ML210 and ML110 , are certified according to European Directive 2004/22CE category MI-004

DN sensore	mm	25	32	40	50	65	80	100	125	150	200
	<i>inch</i>	<i>1</i>	<i>1 ¼</i>	<i>1 ½</i>	<i>2</i>	<i>2 ½</i>	<i>3</i>	<i>4</i>	<i>5</i>	<i>6</i>	<i>8</i>
q_i	m ³ /h	0.16	0.25	0.4	0.63	1	1.6	2.5	4	6.3	10
0,1 q_p	m ³ /h	1.6	2.5	4	6.3	10	16	25	40	63	100
q_p (10m/s)	m ³ /h	16	25	40	63	100	160	250	400	630	1000
q_p/q_i		100	100	100	100	100	100	100	100	100	100

DN sensore	mm	25	32	40	50	65	80	100	125	150	200
	<i>inch</i>	<i>1</i>	<i>1 ¼</i>	<i>1 ½</i>	<i>2</i>	<i>2 ½</i>	<i>3</i>	<i>4</i>	<i>5</i>	<i>6</i>	<i>8</i>
q_i	m ³ /h	0.2	0.32	0.5	0.8	1.26	2	3.2	5	8	12.6
0,1 q_p	m ³ /h	1	1.6	2.5	4	6.3	10	16	25	40	63
q_p (5m/s)	m ³ /h	10	16	25	40	63	100	160	250	400	630
q_p/q_i			50	50	50	50	50	50	50	50	50

DN sensore	mm	25	32	40	50	65	80	100	125	150	200
	<i>inch</i>	<i>1</i>	<i>1 ¼</i>	<i>1 ½</i>	<i>2</i>	<i>2 ½</i>	<i>3</i>	<i>4</i>	<i>5</i>	<i>6</i>	<i>8</i>
q_i	m ³ /h	0.16	0.252	0.4	0.64	1	1.6	2.52	4	6.4	10
0,1 q_p	m ³ /h	0.4	0.63	1	1.6	2.5	4	6.3	10	16	25
q_p (2,5m/s)	m ³ /h	4	6.3	10	16	25	40	63	100	160	250
q_p/q_i			25	25	25	25	25	25	25	25	25

DN sensore	mm	25	32	40	50	65	80	100	125	150	200
	<i>inch</i>	<i>1</i>	<i>1 ¼</i>	<i>1 ½</i>	<i>2</i>	<i>2 ½</i>	<i>3</i>	<i>4</i>	<i>5</i>	<i>6</i>	<i>8</i>
q_i	m ³ /h	0.16	0.25	0.4	0.63	1	1.6	2.5	4	6.3	10
0,1 q_p	m ³ /h	0.16	0.25	0.4	0.63	1	1.6	2.5	4	6.3	10
q_p (1,0m/s)	m ³ /h	1.6	2.5	4	6.3	10	16	25	40	63	100
q_p/q_i		10	10	10	10	10	10	10	10	10	10

MID 004 - MPE CLASS 2 (Maximum permitted error)

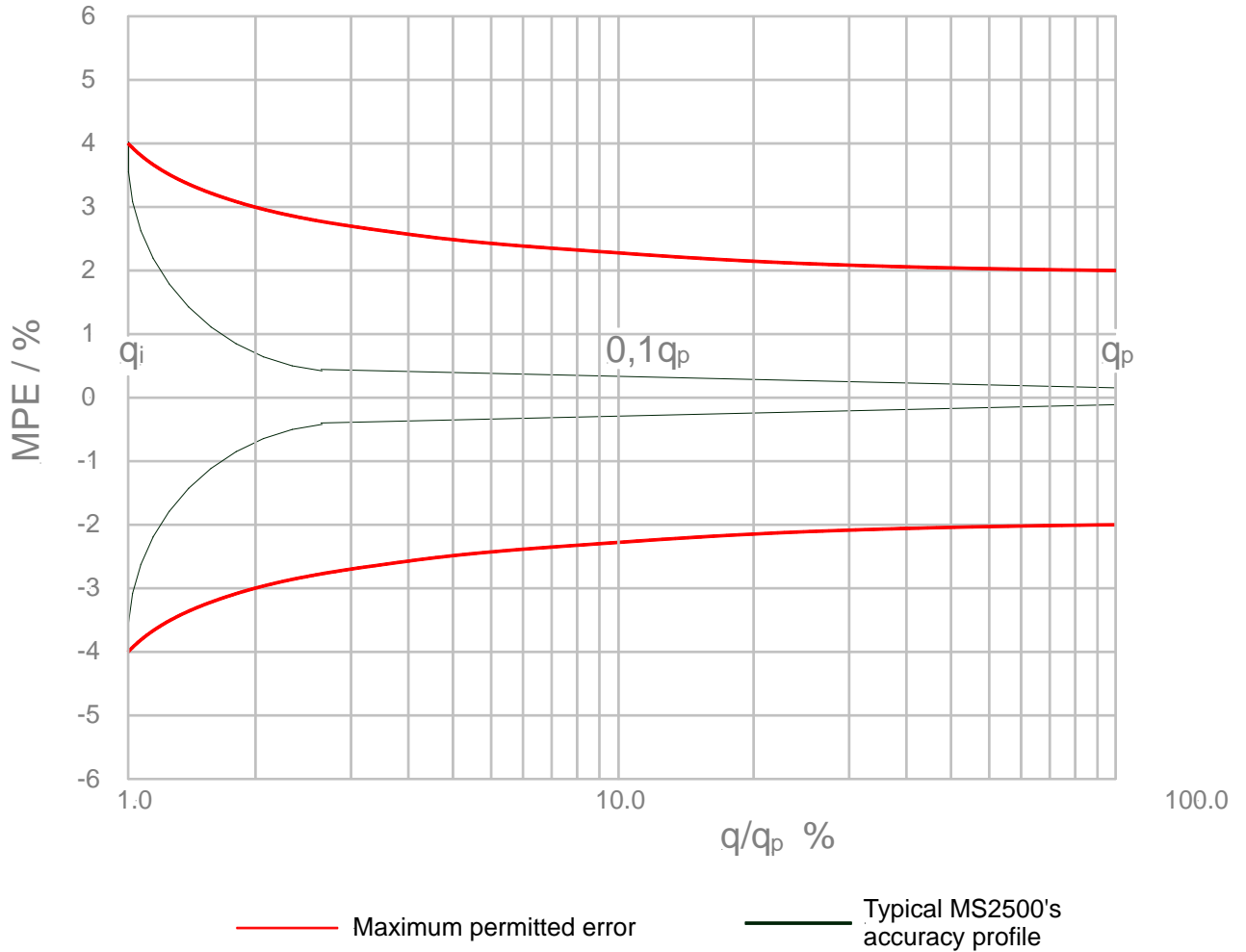

HOW TO ORDER

CODE EXAMPLE	Display	
A	A	Blind execution (without display and programming keys)
	B	Complete with 2 line back light display (each of 16 characters) and 3 programming keys
Housing material / Protection rate		
0	0	Nylon PA6 with fiber of glass / IP 65
	1	Painted aluminum die casting, protection rate IP67
Version		
A	A	Compact version with sensor MS.... (liquid maximum temperature 100 °C)
	B	Separate version for wall mounting, complete with mounting accessories (CABLE C018)
Power supply		
1	1	Power supply : 90 ... 265 V 45/66 Hz
	2	Power supply : 18...63 V dc / 15...45 V ac - 45...66 Hz
	9	Power supply : other
Analogue output		
A	A	Without analogue output
	B	Analogue output 0/4...20/22 mA
Serial Interface		
1	1	Without RS485 Serial Interface
	2	RS485 Serial Interface
	3	Modbus protocol over RS 485 interface
Accuracy		
A	A	Standard accuracy 0,8 %
	B	Special accuracy 0,4 %
	C	Special accuracy (to be defined)
Special Features		
0	0	NONE
	1	WITH ANTICONDENSE CAP



ML110-B0A1A1A0 (Complete code example for order)

The manufacturer reserves the right to make design improvements without notice.