

YOUR PARTNER IN SENSOR TECHNOLOGY

ELEKTRONIK
Ges.m.b.H.

USER'S GUIDE

EE650 - Air Velocity Transmitter for HVAC Applications

GENERAL

The EE650 is designed for highly accurate measurement of air velocity up to 20 m/s (2000 ft/min). The E+E thin film sensor used in EE650 operates on the hot film anemometer principle. The mounting flange offers a continuous change of immersion depth at the duct. The output signal, measuring range and the response time can be adjusted by plugging a jumper on the circuit board. The EE650 air velocity transmitter is dedicated for accurate and reliable measurement in building automation and ventilation applications. For special applications do not hesitate to contact the manufacturer or the corresponding distributor.

CAUTION

- The accurate and reliable determination of the air velocity depends on the correct positioning of the probe. Accurate measurements are only possible if the probe is installed in a location with approximately laminar flow.
- For duct mounting the required inlet and outlet paths has to be observed. More information can be found on www.epluse.com.
- Extreme mechanical and unspecified strain and corrosive environments and condensation must be avoided.

CONNECTING DIAGRAM

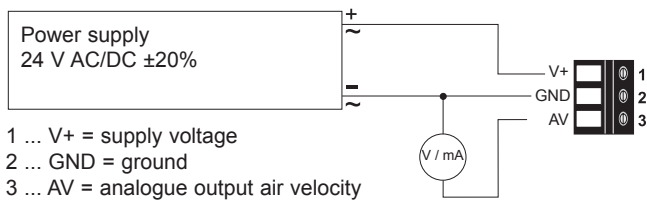

Remote sensor probe

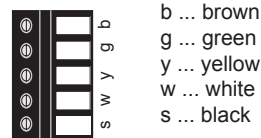

SETTINGS

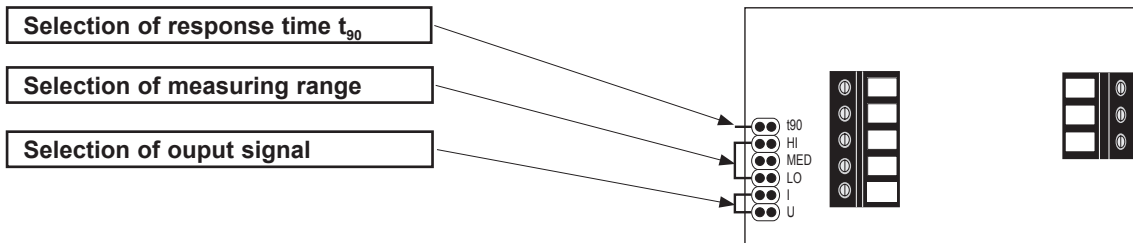

Selection of output signal

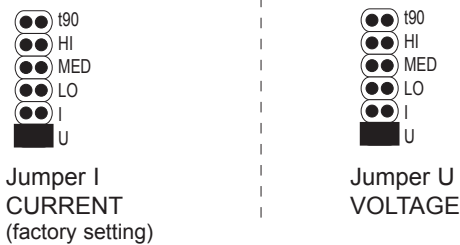

Selection of response time t_{90}

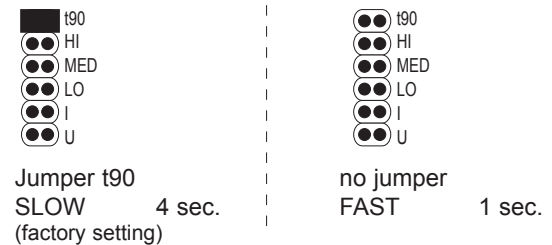

Selection of measuring range

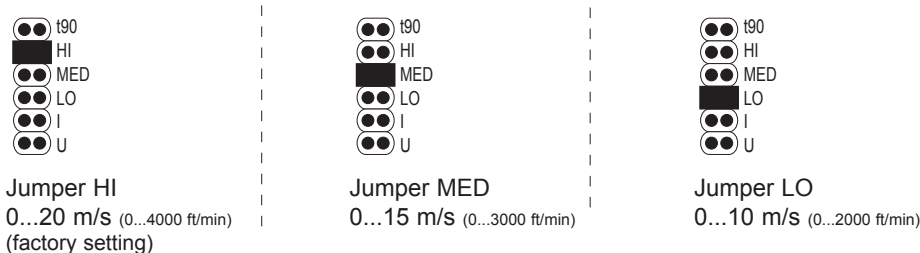

By using the Configuration Software (EE-PCS) to change the output scaling, the jumper has to be on HI.

TECHNICAL DATA

Measuring range

Working range ¹⁾	0...10 m/s (0...2000 ft/min)	
	0...15 m/s (0...3000 ft/min)	
	0...20 m/s (0...4000 ft/min) (factory setting)	
Output ¹⁾	0 - 10 V	-1 mA < I _L < 1 mA
0...10 m/s / 0...15 m/s / 0...20 m/s	4 - 20 mA (factory setting)	R _L < 500 Ω (linear, 3-wires)
Accuracy at 20 °C (68 °F)	0.2...10 m/s (40...2000 ft/min)	± (0.2 m/s (40 ft/min) + 3 % of m. v.)
bei 20 °C, 45 % rF, 1013 hPa	0.2...15 m/s (40...3000 ft/min)	± (0.2 m/s (40 ft/min) + 3 % of m. v.)
	0.2...20 m/s (40...4000 ft/min)	± (0.2 m/s (40 ft/min) + 3 % of m. v.)
Response time τ ₉₀ ^{1) 2)}	typ. 4 sec.. (factory setting) or	typ. 1 sec. at constant temperature

General

Power supply	24V AC/DC ± 20%	
Current consumption	for AC supply	max. 170 mA
	for DC supply	max. 70 mA
Electrical connection	screw terminals max. 1.5 mm ² (AWG 16) ²	
Cable gland	M16x1,5	
Electromagnetic compatibility	EN61326-1	EN61326-2-3
	Industrial Environment	
Housing material	Polycarbonate, UL94V-0 approved	
Protection class	Enclosure IP65 / NEMA 4, remote probe IP20	
Temperature range	working temperature probe	-25 ... +50 °C (-13...122 °F)
	working temperature electronic	-10 ... +50 °C (14...122 °F)
	storage temperature	-30 ... +60 °C (-22...140 °F)
Working range humidity	5...95 % RH (non-condensing)	

1) Selectable by jumper

2) Response time τ₉₀ is measured from the beginning of a step change of air velocity to the moment of reaching 90% of the step.



DIMENSIONS MM (INCH)

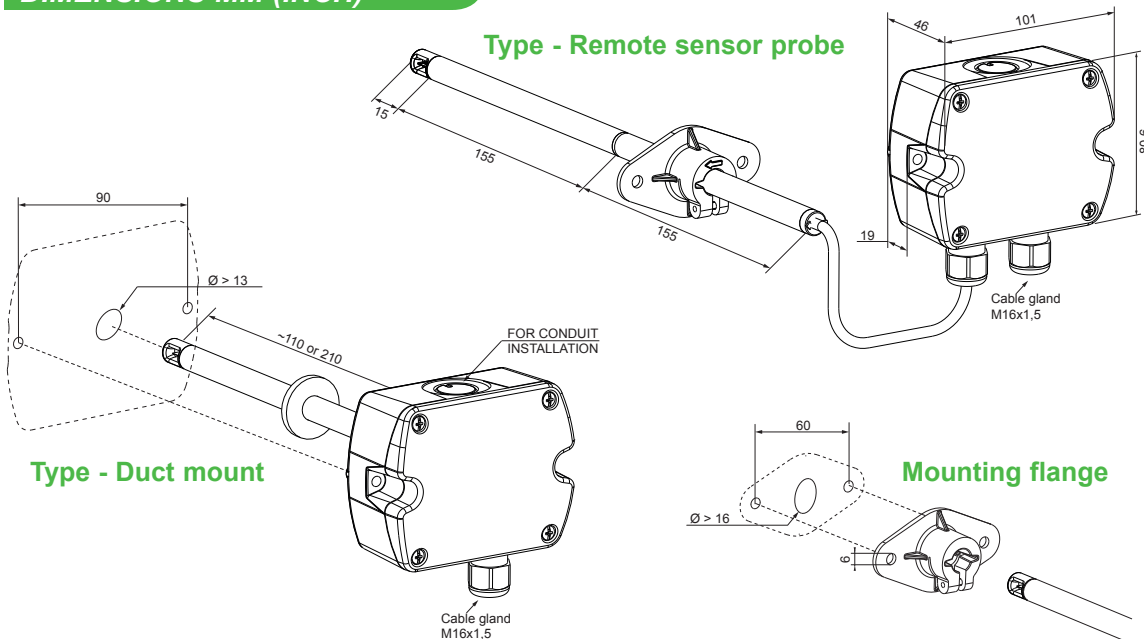

SCOPE OF SUPPLY

- EE650 Transmitter according to ordering guide
- Cable gland
- Mounting flange
- Mounting materials
- Protection cap
- Instruction manual
- Two self-adhesive labels for configuration changes (see user guide at www.epluse.com/relabeling)
- Test report according to DIN EN10204 - 2.2

ACCESSORIES

Product configuration adapter
 Product configuration software
 Power supply adapter

see data sheet EE-PCA
 EE-PCS (free download: www.epluse.com/EE650)
 V03 (see data sheet Accessories)

SETUP AND ADJUSTMENT

The EE650 is ready for use immediately and requires no configuration work by the customer.

If required, the optional E+E Product Configuration Adapter (EE-PCA) and the E+E Product Configuration Software (EE-PCS) can be used for customer adjustment of the air velocity.

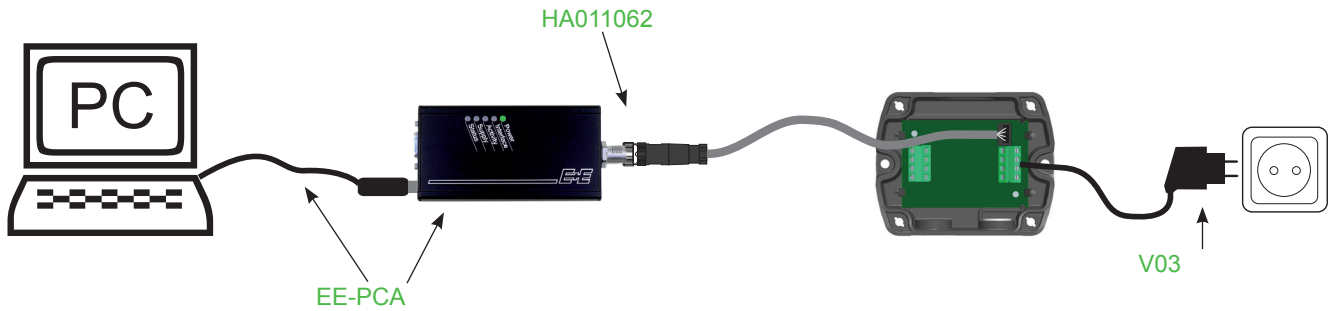

For product data sheets EE-PCS and EE-PCA please see www.epluse.com.

The E+E Product Configuration Software (EE-PCS) is free and can be downloaded from www.epluse.com/configurator.

MOUNTING

Bore for für mounting flange:

Drilling in the wall of the duct:

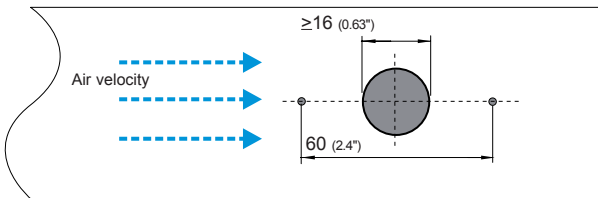

The mounting flange allows for an infinitely variation of the depth of the sensor probe. It is important to ensure that the sensor head is completely submerged into the flow.

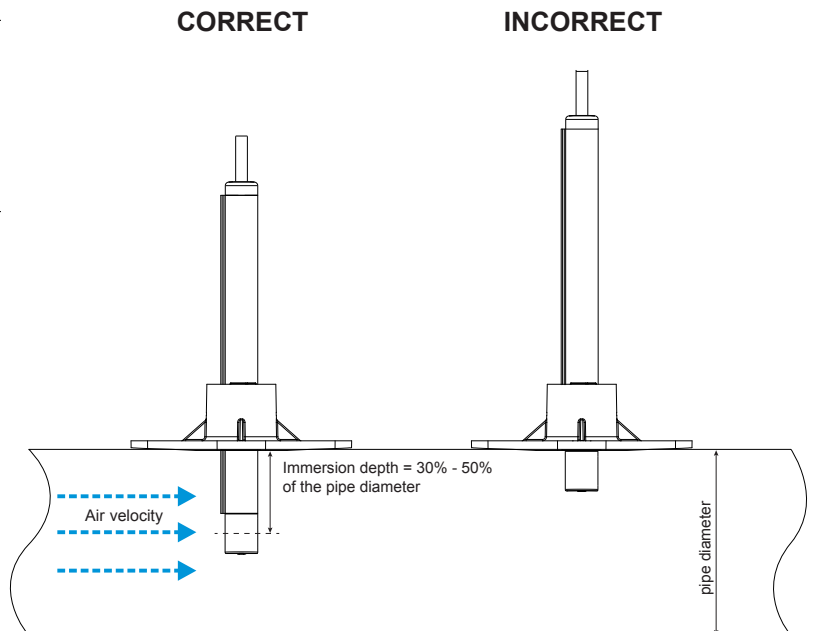

If the sensor probe is installed without a mounting flange, make sure the air velocity sensor is aligned parallel with the air stream.

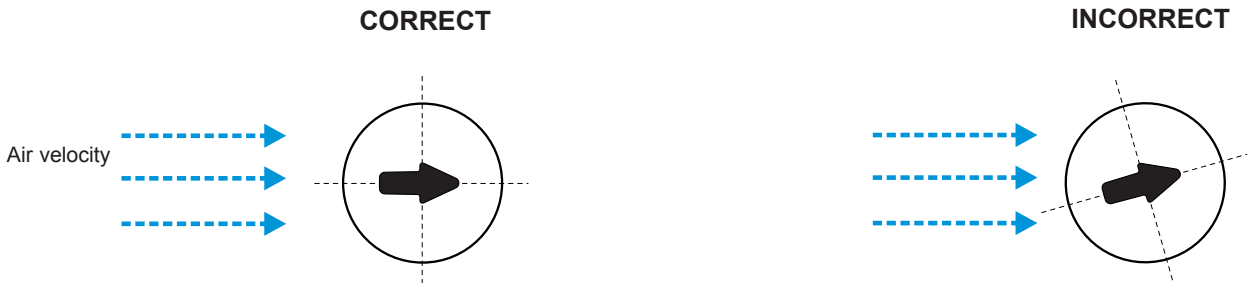

Positioning of air velocity sensor in a ventilation duct

The reliable and accurate measurement of air velocity depends on the correct positioning of the sensor in the ventilation duct. Accurate measurements are only possible if the air velocity probe is positioned at a location with a laminar (to-turbulent) flow.

The required length of the calming section after a fault is a function of the tube diameter D. For a rectangular channel a x b applies:

$$D = \frac{2 \times a \times b}{a + b}$$



Mounting the sensor probe in the middle of the channel.

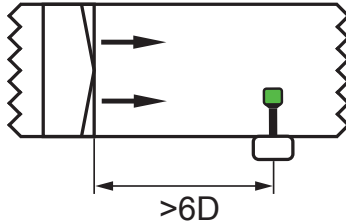
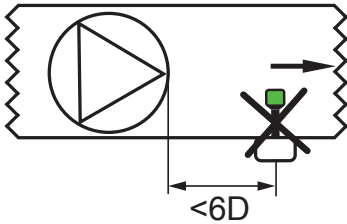

The optimal position is after the filter. Please note sufficient distance.

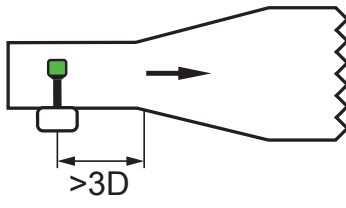
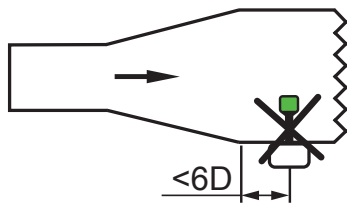

Positioning the probe ahead of diffuser, at a place with high flow rate.

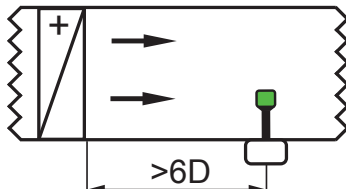
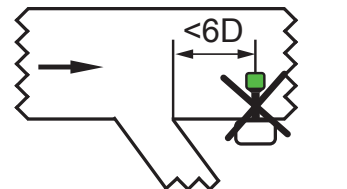

Positioning the probe at a location with a laminar (to-turbulent) flow.

Turbulent flows are caused by pipe bends, branches, behind flaps, flans, air heaters, air coolers or cross-sectional changes.

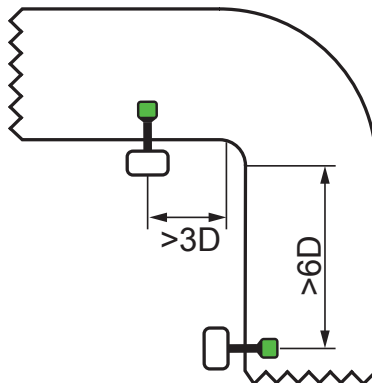
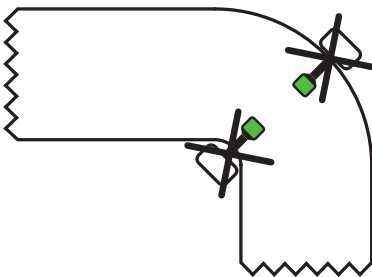

INFORMATION

+43 7235 605 0 / info@epluse.com

E+E Elektronik Ges.m.b.H.
 Langwiesen 7 • A-4209 Engerwitzdorf
 Tel: +43 7235 605-0 • Fax: +43 7235 605-8
info@epluse.com • www.epluse.com
 LG Linz Fn 165761 t • UID-Nr. ATU44043101
 Place of Jurisdiction: A-4020 Linz • DVR0962759

